

WHALEY PRODUCTS INC.

P.O. Box 817, BURKBURNETT, TX 76354

PH: 940-569-4116 FAX: 940-569-4247 WWW.WATERCHILLERSYSTEMS.COM



Air Cooled Portable Chiller Model SAP15-4-2PT

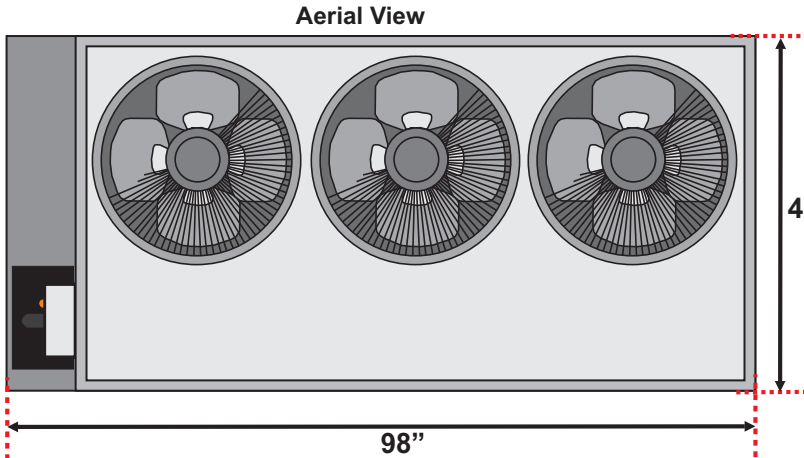

Model #: SAP15-4-2PT
Nominal Tons: 15 Ton
KW: 52.7
BTU/hr: 180,000
Pump Configuration: Dual
Voltage: 460/3
Unit FLA : 33.4
Supply Pump HP: 3 HP
Circ Pump HP: 1 HP
Max Flow: 36 gpm
Insulated Poly Tank Size: 100gal
Length: 98"
Width: 46-1/4"
Height: 85-1/2"
Number of Compressors: 2
Inlet/Outlet Connections: 1ea 1.5"

