

# WHALEY PRODUCTS INC.

P.O. Box 817, BURKBURNETT, TX 76354

PH: 940-569-4116 FAX: 940-569-4247 WWW.WATERCHILLERSYSTEMS.COM



## Air Cooled Portable Chiller Model SAP15D-3-PT

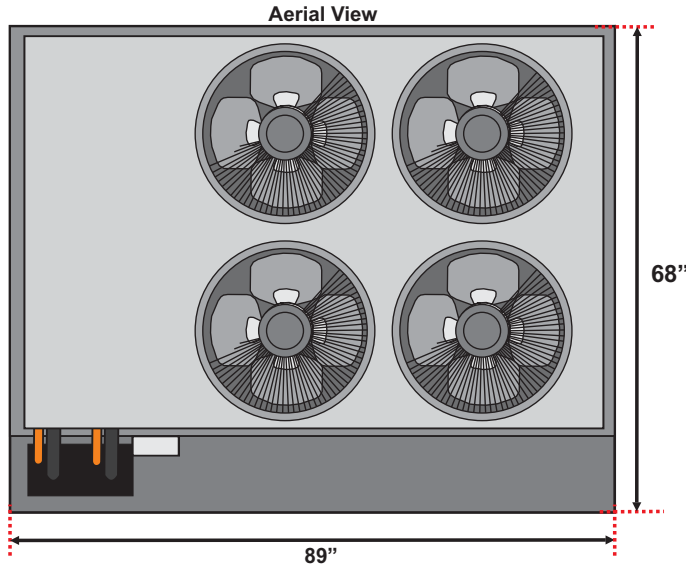

Model #: SAP15D-3-PT  
Nominal Tons: 15 Ton  
KW: 52.7  
BTU/hr: 180,000  
Pump Configuration: Single  
Voltage: 208-230/3  
Unit FLA (1 On Compressor): 38.1  
Unit FLA (2 On Compressors): 69.3  
Supply Pump HP: 3 HP  
Circ Pump HP: N/A  
Max Flow: 36 gpm  
Insulated Poly Tank Size: 100gal  
Length: 89"  
Width: 68"  
Height: 84"  
Number of Compressors: 2  
Inlet/Outlet Connections: 1ea 1.5"

